

**turntablist transcription methodology**

copyright © 2000

john carluccio  
ethan imboden  
raymond pirtle

## contents

intro	front cover
basic staff	1
record movement	1
basic scratch notation	2
scratching to a beat	3
backspinning	4
continuous patterns	5
advanced scratch notation	6
pitch, tones, echoes, effects	7
summary of symbols	7
sample routine (rob swift)	8
blank score	9
outro	back cover

## introduction

While filming the X-ecutioners in their first studio sessions (Asphodel Records 6/97), I found myself struggling to describe an idea I had for a turntablist team routine. Instinctively, I proceeded to scribble down some different line patterns to convey the idea. In retrospect, it's clear that influences as diverse as my familiarity with video editing timelines to my architecture education lead me to seek a visual means of communicating the concept.

In my conversations with DJs Apollo, Rob Swift, Babu and Q-bert, I have been inspired by shared visions of a day when a tool or method could offer DJs a greater capacity for orchestration. For the past year I have collaborated with Ethan "catfish" Imboden, an industrial designer, to develop and refine the system and to seek ways of making it more user friendly. Recently Ethan and I joined forces with Ray "DJ Raydown" Pirtle, a dedicated student of turntablism who had been independently developing a similar transcription method with a focus on complex scratches. This booklet is the first product of this group's collaboration.

Today's turntablists use visible and audible cues to recognize and learn complex techniques from an ever expanding pool of video tapes and live performances. Recent generations of DJs have the ability to recognize and articulate a musical language without the help of visual icons, a talent I hope will never be lost. This system is not intended to replace these abilities but rather to enhance the level of orchestration and musical design.

The possibilities are endless. The reinforcement of information with a visual representation yields an expansion of understanding. The next generation of turntablists, who will emerge using various new methods of transcription, will hopefully discover new techniques and patterns that were never before imagined.

Nevertheless, even with all the technology that will be available, and the most intricate compositions imaginable, the most resonant sound that emerges in a performance is a result of the turntablist's spirit. Your emotion is the soul of your music. Even if you can duplicate the greatest DJs routines, without the same emotion and spirit the performance will be empty.

Please use this method responsibly. Find your spirit and release it through the turntables! - John Carluccio

## why transcribe?

Communication facilitates progress. Turntablist Transcription Methodology (TTM) offers the benefits of language to a culture that currently has only an aural tradition.

As a creative tool and a mnemonic, TTM assists individual artists in developing music. Between musicians, it serves as a lingua franca. The language provides a method for documenting the progress of the art and preserving its accomplishments. It enables techniques to be attributed to innovators. References to prior work will be visually as well as audibly evident. Biting is readily apparent, and copyrighting of compositions is now feasible. TTM promotes the evolution of turntablism by providing a new perspective on existing techniques. Structures in music are revealed and can be analyzed when represented graphically; new structures can then emerge from this expanded understanding. TTM enables publishing and distribution. Transcribed scratches can be made available in stores, online, in liner notes, or on a record sleeve. Techniques and routines can be communicated anywhere a graphic can be transmitted – via email or fax, on a web site or a napkin, in graf or posted on a telephone pole. Collaboration can occur anywhere. TTM also supports the appreciation of the art. Even an uninformed audience (judges?) can begin to comprehend the intricacy of a turntablist's composition when its notation is presented to them in real time.

In this handbook we outline not only a system for notation, but also the logic behind the system. I invite you to find fault in the logic and to overcome its shortcomings with your ingenuity. Our only request is that as you progress, you share your discoveries. The natural evolution of TTM in the hands of the turntablist community will carry it far further than would the efforts of a few individuals, regardless of their dedication.

- catfish

## potential

The turntable is a musical instrument which can be played in an infinite number of ways. Whether you're mixing at parties, or cutting the baseline in a quartet, you are creating something new through the manipulation of sounds. Our instrument can invoke a set of african drums by means of rhythmic cuts and, in the click of a fader, play a guitar (or even sitar) melody through the changing of the record's speed. We can rock dancehalls and Carnegie Hall. The techniques and stories passed down to us by our ancestors will be re-told and remixed on the vinyl disks of the past as well as the hard and floppy disks of the future. The originators of this craft, those whom we've praised and forgotten, are our foundation and have given us the tools with which we can build. Hip-Hop was created through the melding of sounds, ideas, and passions, and in this spirit we must continue to express ourselves through our music.

- Raymond Pirtle

## basic staff

The basic TTM staff has been designed specifically for notating turntable-based music. The format of the staff used in this handbook is optimized for 4/4 time (the standard time signature used for hip-hop beats), but the system can be applied to any time signature.

TTM is derived from a graph of the rotation of the record vs. time. The vertical axis of the staff represents the rotation of the record, and the horizontal axis represents time (subdivided into measures, counts, 1/2, 1/4, 1/8, and 1/16 notes).

### To notate playing a sample from a record:

- See where the segment begins and ends on the record (in this example we selected the word "fresh")
- Write the sound onto the "sample line" on the left side of the staff. The horizontal lines that extend from of the sample line into the staff will help to indicate specific areas of a sample to be manipulated (start, end, different syllables, etc.)
- Chart the sound being played over time. On the staff, begin a line at the time the sample should begin. Continue the line to the point that represents the duration and the amount of rotation that is desired. The horizontal distance is determined by the amount of time it takes to play the sample, and the vertical distance is determined by the portion of the sample being used.

In the example to the right, the sample begins playing a 1/4 note from the beginning of the measure. The line created by playing "fresh", it is about 5 units high (the length of the segment from the record) and about 5 units long (the duration of time it took to complete the segment -- a little over a 1/4 note).

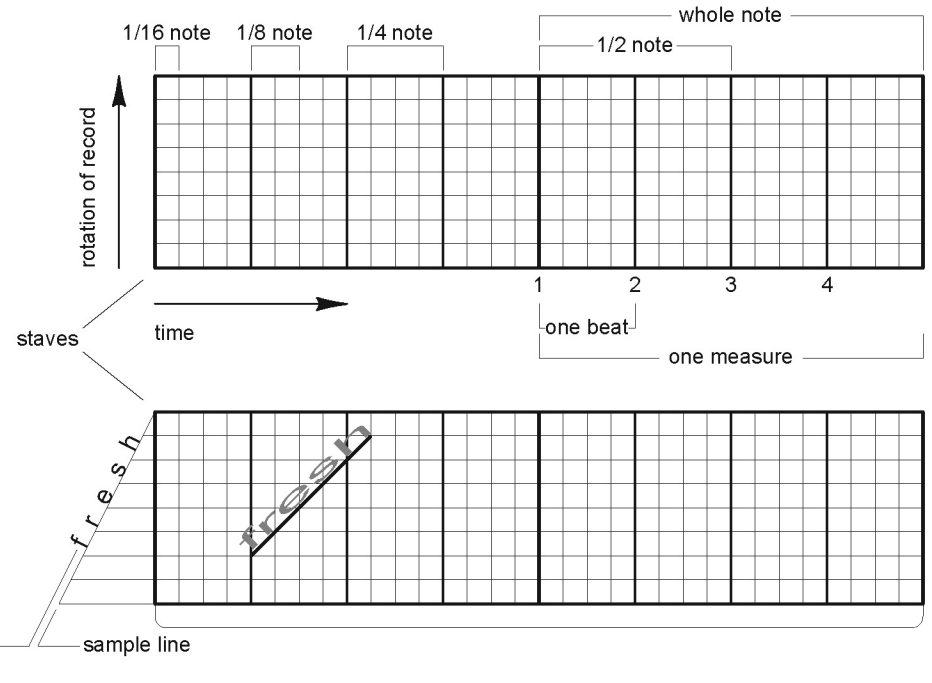
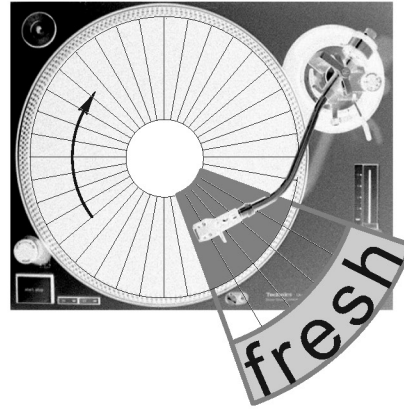

## record movement

When a record is played **forwards** (clockwise rotation) the line has an upward slope.



forward movement = upward slope

The **slower** the record rotates, the more counts (the longer the time) it takes for the sample to play. On the staff, this means that the line representing the motion of the record gets less steep. Conversely, the **faster** the sample is played, the steeper the line.

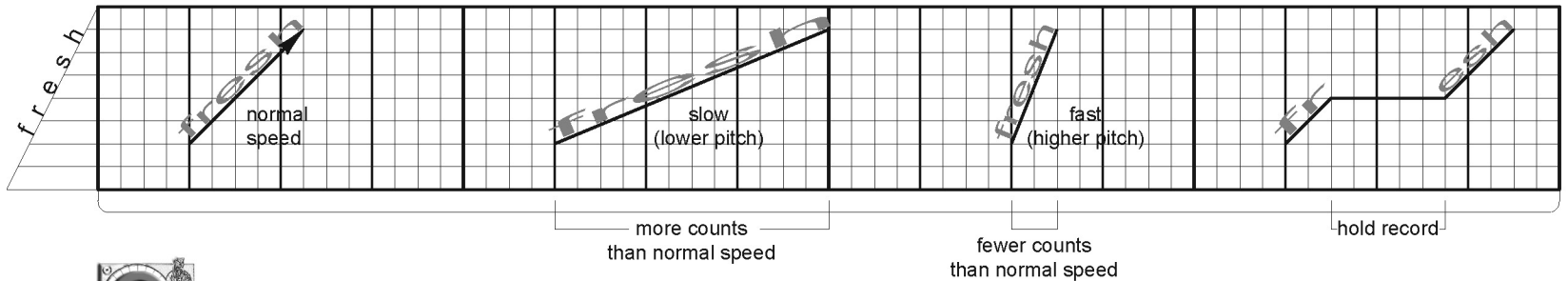

When a record is played **backwards** (counter-clockwise rotation) the line has a downward slope. Again, the faster the motion of the record, the steeper the slope of the line in the notation.



backward movement = downward slope

When a record is **held still**, the line is horizontal. This indicates that there is no rotation during the time that the record is held still.

It is important to note that a vertical line on the staff is not meaningful because it represents a motion occurring in zero time. Likewise, since two different scratches can not occur simultaneously on a single turntable, no two scratches should overlap in time on the staff.

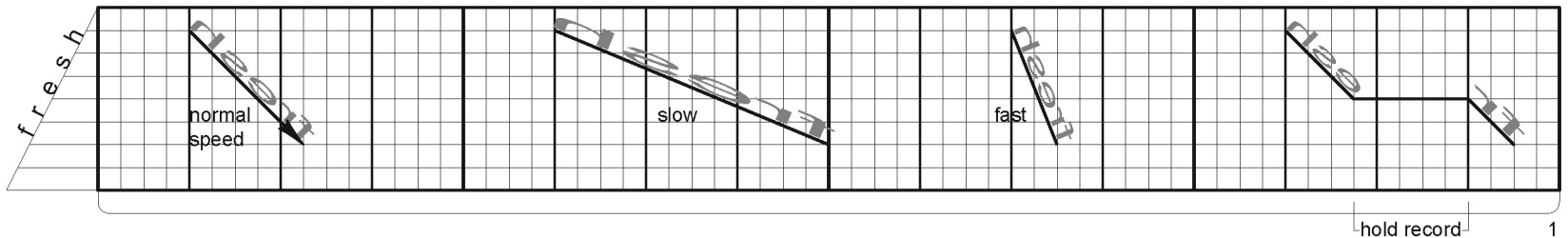

## basic scratch notation

**baby** - (rub) moving the record back and forth without using any mixer controls to crop the sound

**forward** - (cut) similar record motion to baby, but a mixer control (fader, level, switch) is used to cut off the sound during the pull back. (Originated by G.W. Theodore, made famous by G.M. Flash)

**military** - basic rhythmic scratch pattern comprised of forward scratches interspersed with rubs. Typically the record hand moves in a consistent back and forth motion while the mixer hand cuts on and off the sound.

**scribble** - very quick baby scratch using a small portion of the record. Usually accomplished by vibrating a fingertip on a single spot.

**stab** - (jab, scrape) scratch that is pushed or pulled fast creating a higher pitched sound. As with forward scratch, the sound of re-cueing is not heard.

**drag** - scratch that is pushed or pulled slowly, creating a lower pitch sound.

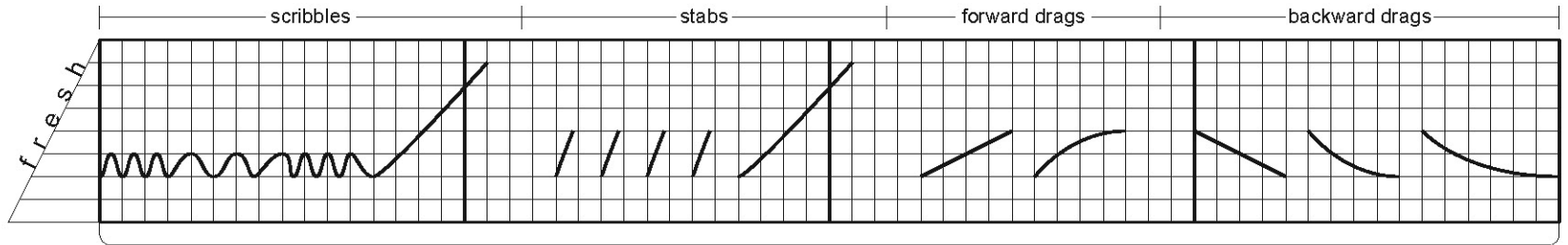
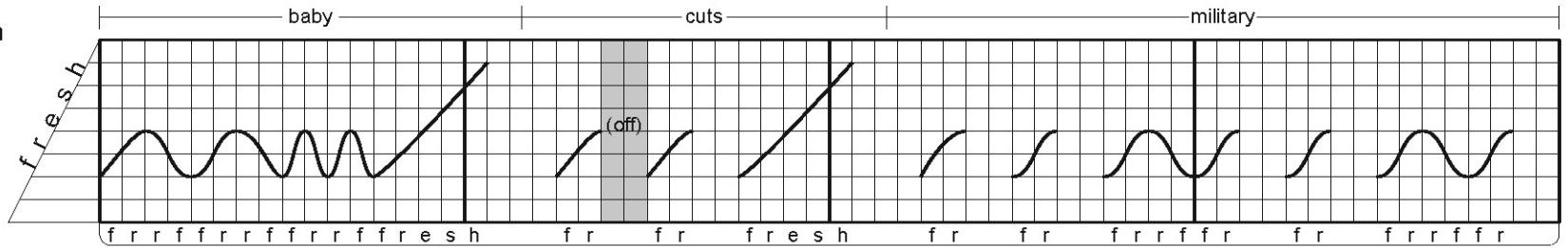

**chirps** - series of high pitch pushes and pulls creating "chirping" sound not unlike that of a gleeful bird on a fine spring mom. The sound is cut off when the record movement is changing direction so that a single tone is emitted from each forward or backward stroke of the record. The pitch of the chirp rises and falls as the record is oscillated faster or slower.

**transformer** - the record is pulled back and forth while the fader is steadily opened and closed. The sound is cut on and off several times during each forward or backward stroke of the record so that multiple tones are emitted in each cycle. Like chirps, the sound is cut off when the record is changing direction. This results in a chopped sound that varies in pitch (similar to the sound made by Optimus Prime, noble leader of the Transformers). (Introduced by Spinbad, made famous by Jazzy Jeff & Cash Money)

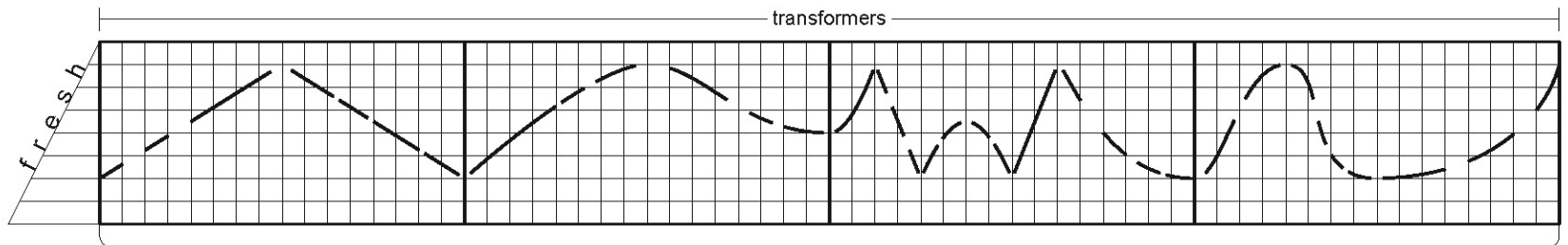
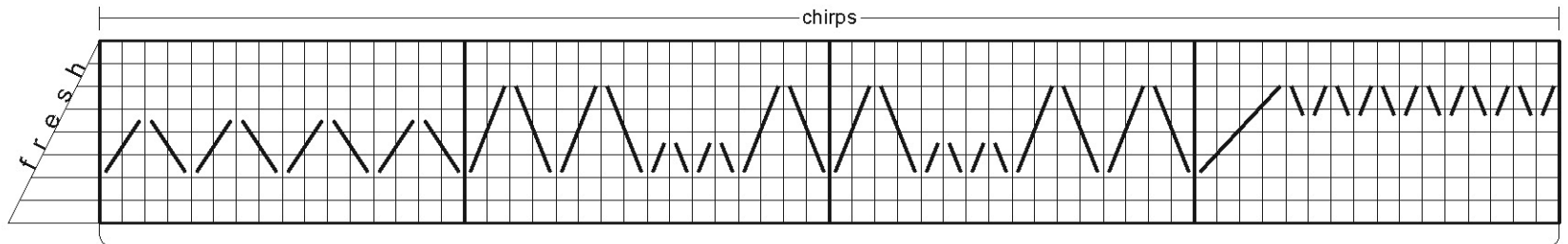

## scratching to a beat

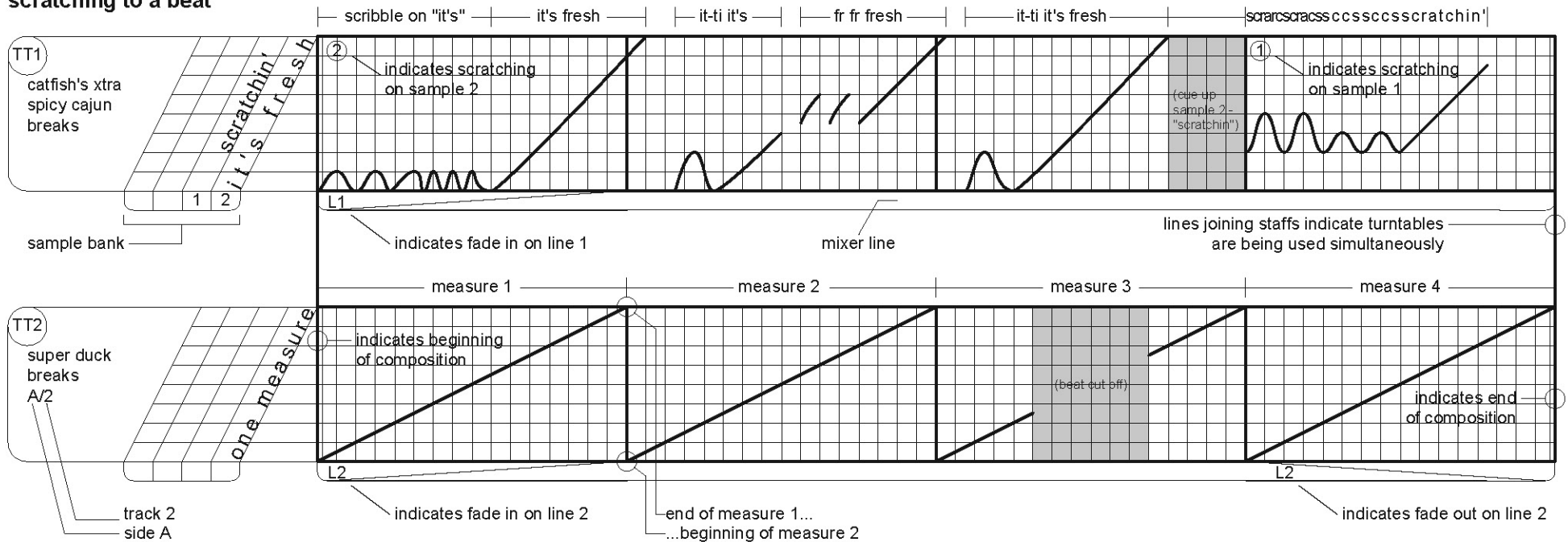

Above is the transcription of two turntables in use -- Turntable 1 (TT1) is used for scratching over the beat being played on TT2. One staff is shown for each turntable being used. The vertical bar connecting the two staves indicates that they are played simultaneously.

An area has been added to the left of the basic staff to provide room for noting the record and track (and if necessary the number of revolutions into the track for a given sample). Additional space has been created so that multiple samples at different locations on the record can be referenced in the score. Typically scratches are written and numbered in the order that they appear on the record -- sample 1 comes before sample 2, etc. The numbers are then used on the staff to indicate a change in the sample being manipulated. The transcription of the scratching on TT1 illustrates the use of the multiple sample line section or "sample bank".

Beneath each staff is the **mixer line**. This area is for additional notes regarding mixer controls and other manipulations effecting the performance. In the example above, fading up Line 1 (L1) and L2 at the beginning of the score, and fading out L2 at the end are noted in the mixer line.

The example shown below represents the same score as above, but the notation has been compressed to occupy only a single staff. When there is very little manipulation of a turntable (as is often the case when scratching to a beat), the staff for that turntable can be eliminated; the few manipulations that are required can be summarized in the mixer line of the active turntable. This compressed notation provides a significant space savings.

## condensed notation

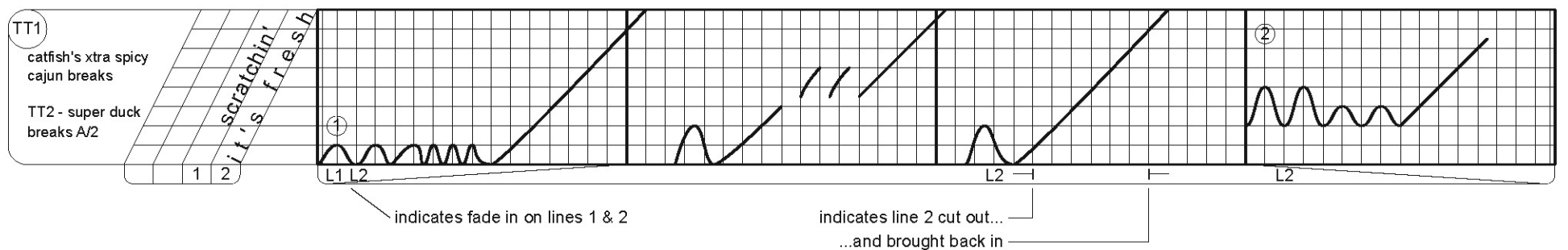

## backspinning

**Backspinning** is taking a pair of records and repeating the same portion of each record alternately — in effect "looping" the segments together continuously. A common example of backspinning is notated below. One measure of the beat is played on turntable 1, then the same measure is rubbed in and played (on beat) on turntable 2. While the measure is playing on turntable 2, the same measure just played on turntable 1 is backspun and re-cued. At the end of the measure played on turntable 2, the first two counts of the measure is played on turntable 1. This segment is then repeated from turntable 2. This pattern of alternating between the two turntables by playing a segment on one turntable while recuing the other is the essence of "backspinning". In the example notated below, the segment being repeated becomes shorter and shorter until only the first count of the measure is being repeated. This rapid back and forth pattern continues for 4 measures.

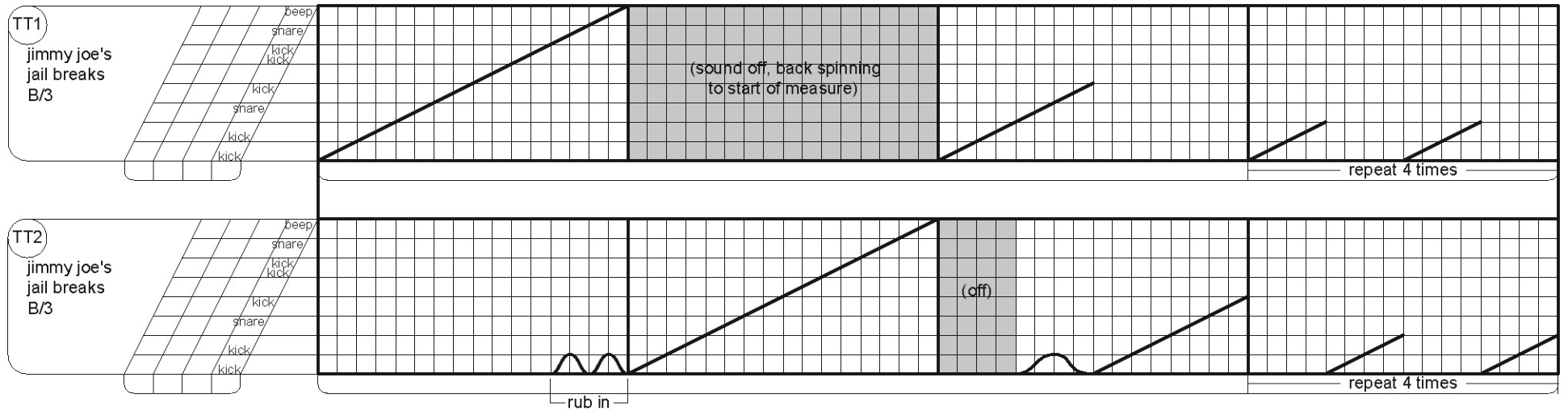

## drum symbols

The notation below describes the same composition as above, but introduces symbols for several standard components of a drum beat. The symbols can be used to clarify a backspinning, juggling, or drumming routine. It is not necessary to notate extraneous sounds if they don't play a significant role in the routine. A pair of **repeat symbols** are also introduced in this example. These symbols replace the long hand notation shown in the final measure of the example above.

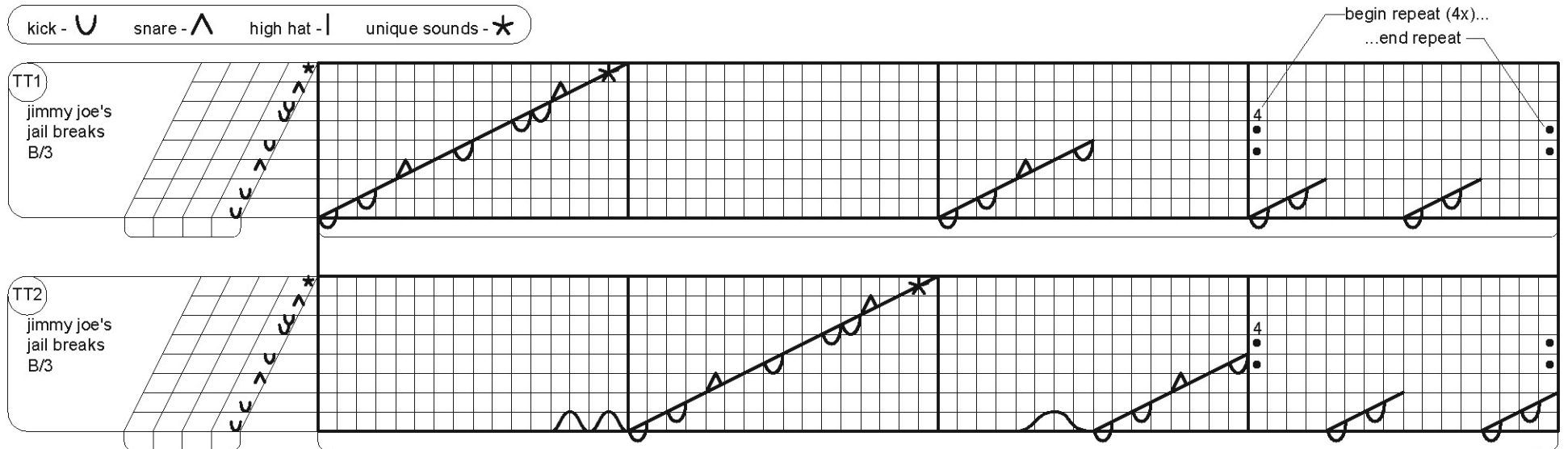

## continuous patterns

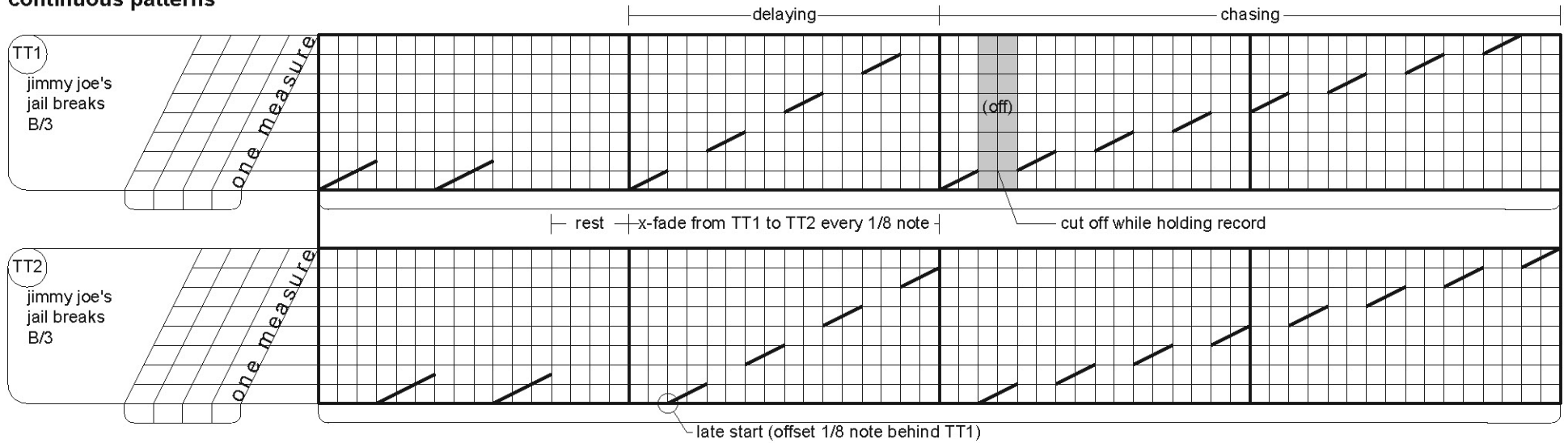

The example above illustrates two techniques: delaying and chasing. **Delaying** consists of playing two copies of the same record at the same time, but offset by a short amount of time (typically 1/8 note). The delay effect then occurs when the cross fader is flipped between the two channels at regular intervals. Typically the interval of the cross fader movement matches the interval of the offset between the two records. In the example above, both the offset between the records and the interval of the fader movement are 1/8 note. **Chasing** is similar to the delaying, but between each interval of record play, the record is tapped or held for a brief moment. This slows down the tempo of the beats by adding a consistent pause after every interval of sound. In the example above, the pause, the interval of the fader movement, and the interval of record play are all 1/8 note.

## condensed notation

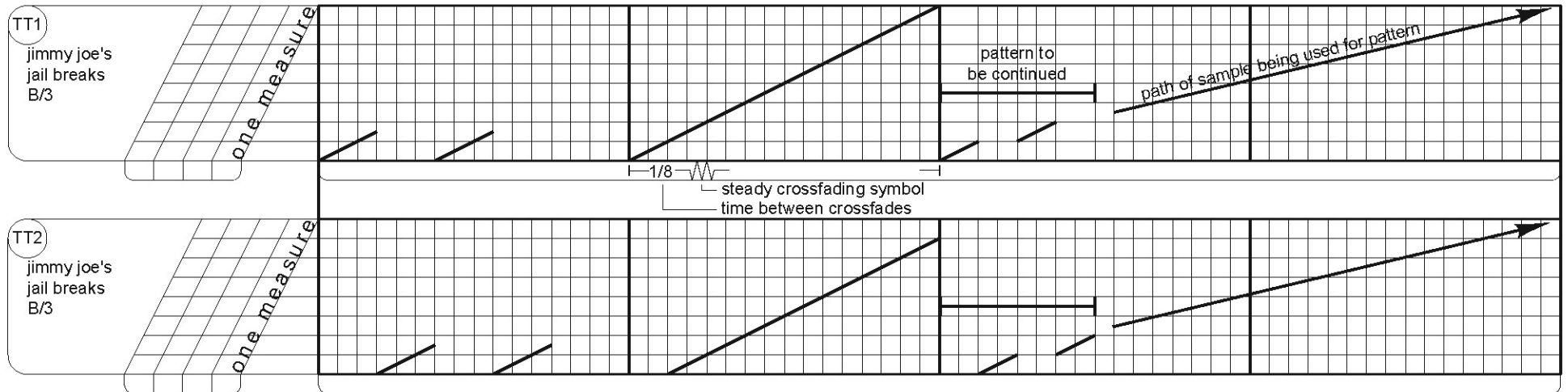

The example shown immediately above represents the same score as at the top of the page, but the notation has been condensed with the use of the steady fader symbol and the continuation symbol. The condensed notation for the delay is created by first charting the sample to be used, then noting on the mixer line the amount of the delay (1/8 in this example) beside the steady crossfading symbol, and finally marking the beginning and ending points for the steady fader pattern. In instances (such as chasing) where there is a constant mixer pattern being repeated while the record(s) continue to play, the notation can be condensed with the use of the **continuation symbol**. To show continuation, draw enough of the pattern for it to be clear what is to be continued, then draw a horizontal bracket over the established pattern. Next, extend a line to indicate the general playing path and termination of the pattern.

## advanced scratch notation

Many advanced scratches require breaking the sample sound with very rapid fader movement. Generally a turntablist will bounce the fader between the thumb and another finger (or several other fingers) to achieve this extremely rapid off and on motion. The very short break in the sound from the record is commonly referred to as a click. Simply put, a **click** is the break in the sound caused by the closing and opening of the fader in as little time as possible. Clicking is an essential technique for many advanced scratches and it requires a special notation.

Also crucial for understanding advanced scratches is the concept of the open fader scratch. **Open fader** scratches are scratches which begin and end in the open (or on) fader position. Examples of open fader scratches include baby scratches, scribbles, flares, and orbits. The open fader scratches are unique in that the sound they produce includes the sound generated by the change of direction of the record during the back and forth scratching motion. This sound is essential because at the exact point where the record changes direction, the record is momentarily completely motionless. The instant where the record is still creates an extremely short period of silence -- a **phantom click** -- which breaks the sound of the scratch without requiring any movement of the fader. The phantom click is the reason that the swift back and forth motion of a baby scratch creates discrete bursts of sound.

The **flare**, a scratch introduced by DJ Flare and made popular by DJ Q-Bert, is a good example of the impact of an open fader scratch. A flare begins with the fader open, and consists of a simple forward and back motion with the record. As shown in the diagram below, a click is placed in the middle of the push forward and another click is placed in the middle of the pull back. Unlike a chirp or a transformer, the change of direction of the record is heard. The resulting phantom click creates the illusion that the sample is being clicked twice as many times. In this flare which has only two clicks, the phantom clicks make it seem as though there are four.

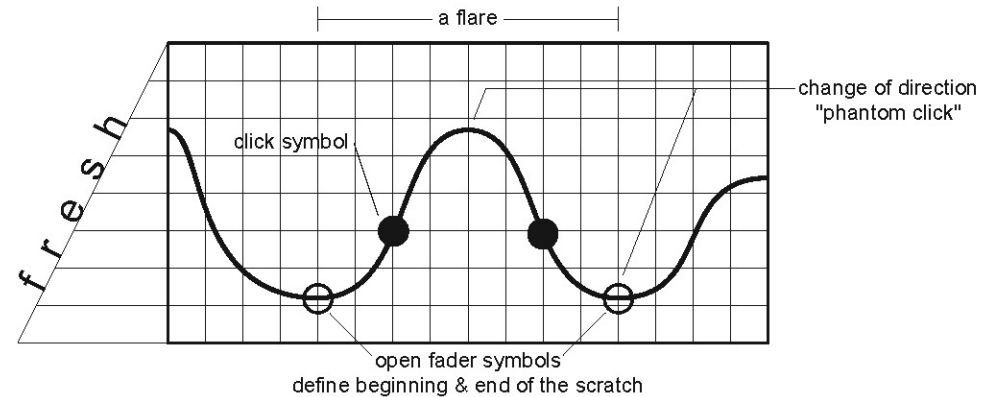
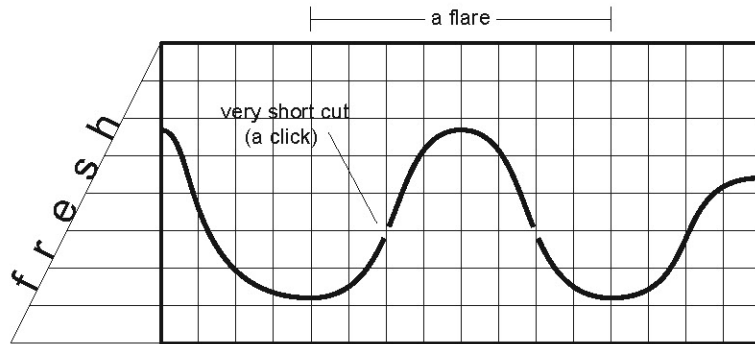

On the upper staff to the right are notations of closed fader scratches using both basic and advanced scratch notation. With these examples it becomes clear that there are advantages to using the advanced notation -- the clicks are both easier to read and to write.

The **crab** (invented by DJ Q-Bert) is a fader technique for producing a very rapid series of clicks. The key to the crab is to bounce the fader between the thumb and each of the other four fingers in sequence (pinky, ring, middle, pointer). The result is an extremely quick "four-click" scratch. Visually, the fingers produce a rolling motion which resembles a fast-crawling crab if you're really really stoned.

On the lower staff to the right are notations of open fader scratches using advanced scratch notation. Each of these scratches is separated by open fader symbols. Since these scratches are connected to each other, they share their open fader symbols with their neighbors. Though in this case the open fader symbol doesn't signify an action on the mixer, it serves to break an incomprehensible sequence of clicks into an understandable series of standard scratches.

### closed scratches

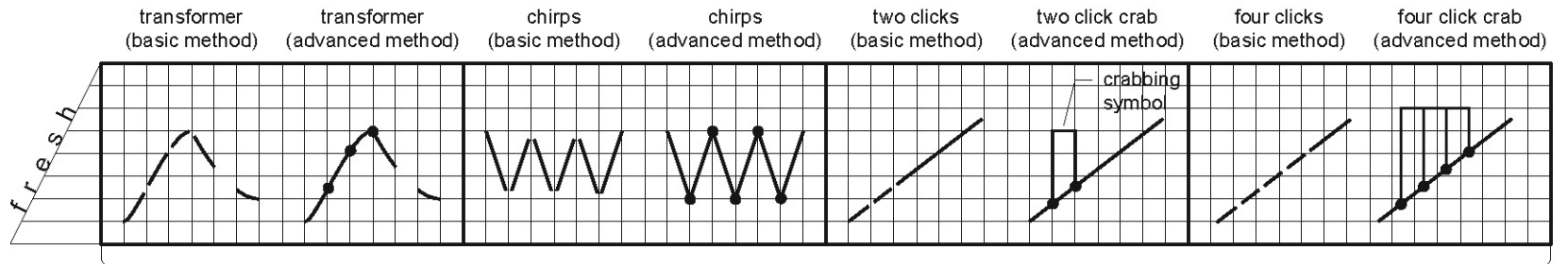

### open scratches

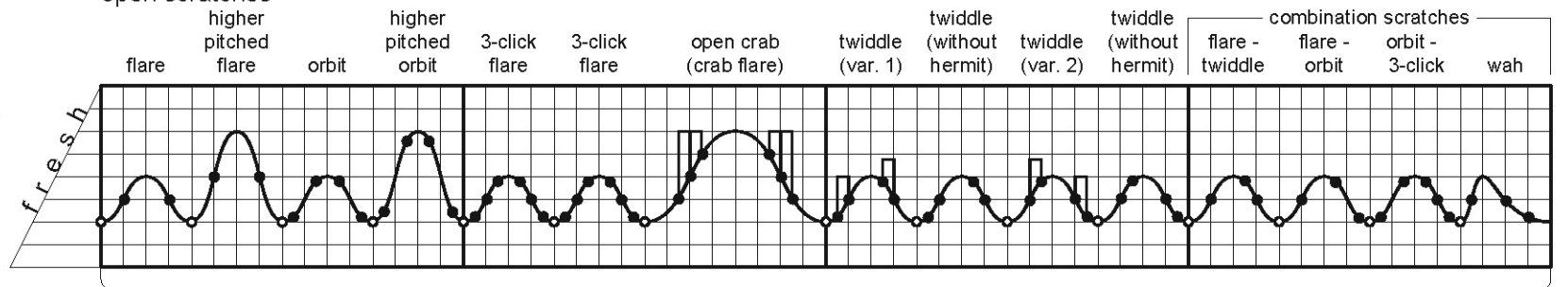



## tones, echoes, and effects

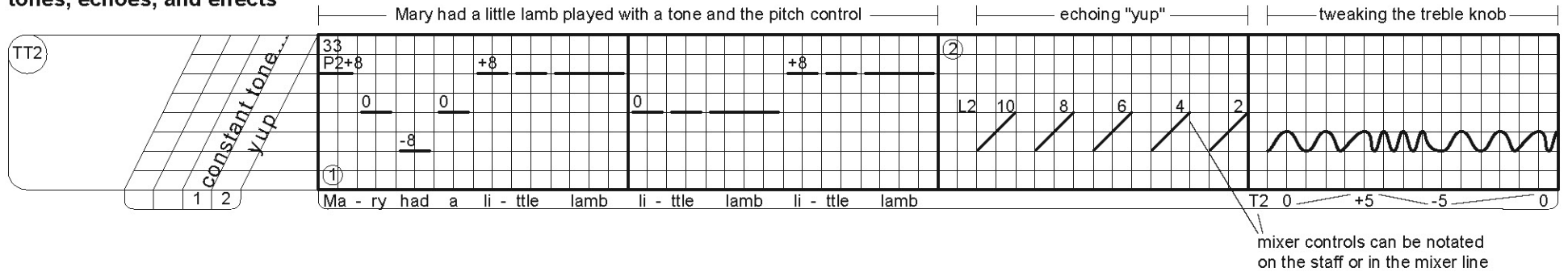

A melody can be created by changing the playback speed of a sample to alter its pitch. A common method for achieving this effect is to use the **pitch control slider** and **33/45 button** on the turntable to control its speed. In the example above, one measure of the melody of "Mary Had A Little Lamb" is played by adjusting the pitch control while playing a constant tone. The rhythm of the melody is shown with broken lines indicating the duration of each note. The lines are placed higher or lower on the staff based on their relative pitch -- this helps give an indication of the tune being played. The symbol for the pitch control is the letter P followed immediately by the number of the turntable being affected. The exact position of the pitch control slider is then given as the percentage of increase or decrease of the rpm. Generally, it is not necessary to repeat the name of the control being manipulated (in this case P2) for subsequent changes to the same control.

The second half of the example above illustrates how to notate an **echo** and a manipulation of the **tone knob** on a mixer. The notation of the echo shows the effect being created by cutting a sample repeatedly with the line 1 level (L1), each time returning to a lower volume. The manipulation of the tone knob is shown by specifying the tone knob for channel 1 (T1), then giving a sequence of settings written in the mixer line. In between the numbers are lines indicating the direction of change of the tone -- these are optional markings that may assist a performer in grasping the notation at a glance.

With all of these examples it is important to understand that the notation of the mixer control can occur in the mixer line or on the staff -- which ever is clearer or more convenient.

## adjusting time scale

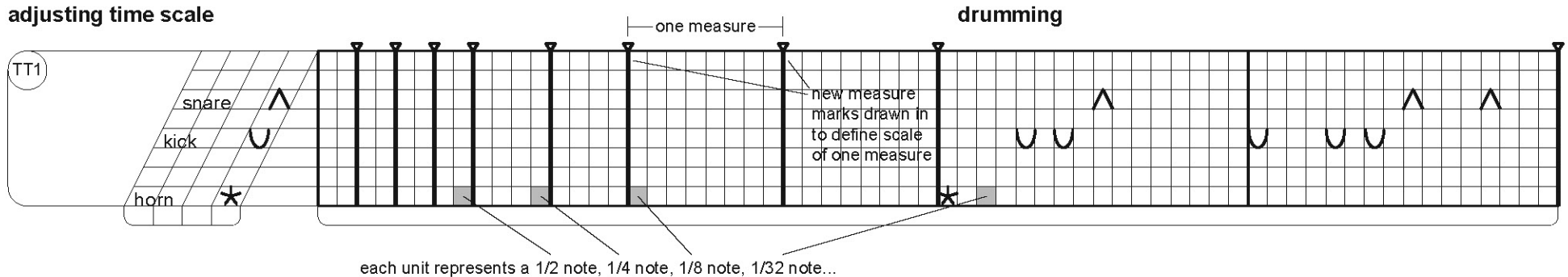

So far in this handbook, the illustrations have shown a staff with each measure broken down into 16 units -- 1/16 notes. While this staff is an appropriate scale for many techniques and compositions, there are instances where it is desirable to **adjust the time scale** to show more or less detail. The example above illustrates how to change the scale of a measure by drawing in new measure marks. This technique can be used to condense measures (as in the first 8 measures in the example) or expand measures (as in the final measure in the example). The last measure of the example above illustrates that when **drumming** (creating a beat by rhythmically cutting samples of percussive sounds), the drum symbols can be used on the staff without drawing any accompanying record motion lines. Using this symbolic notation can save time, and help to clarify the composer's intent.

## summary of symbols

turntable	TT	hamster switch	H	click	●	crescendo	repeat
pitch control	P	tone	T	snare	^	open fader	⋮
cross fader	F	effect	E	high hat		crab	⋮
fader on 1	F1	start	⊕	unique sound	*	steady fader	↗
volume fader	V	stop	⊖	measure mark	▼		
line/phono switch	L	power off	⊘				

TT1 Chorus  
super duck breaks  
TT2 - toasted marshmallow breaks B/5

1 2 3

note: samples 1, 2, 3, and 4 are consecutive on the record

2nd verse only

TT1 Verse 1

TT1 Verse 2

TT1 Verse 3

L2

TT1 Verse 4

3

TT1 Finale

what is it

scratchin'

L10 6 3

F1

Handwriting practice sheet with six rows of grid paper. Each row features a slanted grid on the left and a horizontal grid on the right. The horizontal grid is divided into four equal-width sections. Each row has a circular punch hole on the left side.

## tomorrow

Turntable Transcription Methodology will always be a work in progress. Even after centuries of evolution, modern composers continue to reshape the traditional musical staff and notations. It is not possible for us to foresee the future of turntablism, nor is it meaningful for us to attempt to dictate a system for all others to follow. Notation of turntable based music will develop as organically as turntablism has, with influences from throughout the growing global community of artists who shape our culture. With new techniques will come new transcriptions.

This project is an open source effort; your contributions will help to shape TTM into a powerful and efficient means of communication. Fight it, defend it, tweak it, trash it -- all will assist its evolution. We will be constantly expanding and refining this system as your response rolls in. Also note that there are other systems out there -- Doc Rice's and A-trak's to name a few. Our hope is that within the coming years the systems will build off of one another to arrive at common language that connects us all.

We plan in the coming months to conduct a number of hands-on Q&A sessions to provide instruction in the use of this method. Additional assistance will appear on the web at [www.battlesounds.com/ttm](http://www.battlesounds.com/ttm). We will be making the latest versions of this handbook and blank scores available for download.

Version 2.0 of the TTM booklet will incorporate:

- musical scales and octaves
- group / crew / symphonic orchestration
- notation for advanced beat juggling techniques
- mad scratches: hydroplaning, tweaking, 8 finger crabs, phantom flares etc.
- more sample routines from your favorite turntablists

For questions, comments, and to let us know what else you'd like to see, hit us at: [ttm@battlesounds.com](mailto:ttm@battlesounds.com)

---

## john carluccio

John Carluccio is a Brooklyn based artist who is best known for directing, editing, and producing the Battle Sounds Hip-Hop DJ Documentary film project. The film's inspiration was based on John's love and admiration for new "noises" / audio languages, and the dedication of the battle DJ. The critically acclaimed film has appeared at the Whitney Museum of American Art, Smithsonian Institute, and The Rock n' Roll Hall of Fame. John also coordinates the annual Battle Sounds Turntablist Festival, which celebrates the art of Turntablism via screenings and turntable performances. John was educated in the field of Architecture at Pratt Institute, where at time he Deejayed for the WPIR radio show "Organize Noise". As a photographer, his work has appeared in Vibe's History of Hip-Hop, Spin Magazine, XXL, and on album covers, including Rob Swift's "The Ablast". Other video credits include X-ersize#1 and Hop-Fu (Kung-fu over Hip-Hop beats). John continues to shoot video and film projects in New York City and is currently developing new programs for television and internet broadcasts.

John can be reached at [john@battlesounds.com](mailto:john@battlesounds.com)

## ethan imboden

Ethan began manipulating records in 1984 under the name DJ Funk-E. Back then, he was no joke. Today he prefers the moniker "catfish" and limits his turntablism to living room antics. Catfish studied electrical engineering as an undergraduate at John Hopkins before moving to New York to pursue a Masters of Industrial Design at Pratt Institute. Inspired by the New York turntablist scene, his master thesis Beats from Scratch focuses on the design of next generation mixers and turntables that reflect the dramatic evolution of turntablism. Since graduating from Pratt Institute, catfish has been working in Manhattan with product design firm Ecco Design, Inc. In the coming months he will be moving to San Francisco to join Alchemy Labs. As an industrial designer, catfish has worked for such diverse clients as Bausch & Lomb, Colgate, Herman Miller, and... John Carluccio. His creations have been featured in ID Magazine, and are in the permanent collection of the Chicago Athenaeum. In recent years he has received numerous Good Design awards which means that his designs are really, really... good.

catfish can be reached at [catfish@battlesounds.com](mailto:catfish@battlesounds.com)

## raymond pirtle jr.

Raymond discovered the phonograph at the age 14. His mentor, DJ Picasso, taught him the arts of the tables and gave him the name "Raydawn". Being inspired by the dj's of the Atlanta battle scene in the mid-90's, Ray began to focus upon the performance elements of djing. Eventually, he left his high school jazz ensemble to pursue turntable instrumentation full time. He has participated in various battles as well as launched a series of compilation cd's under the name Subterranean. Raydawn is an information systems major at New York University's Stern School of Business and is currently pushing for the induction of turntablism into his school's music program. As of now, he is working on writing and recording scores for his multi-piece turntablist ensemble, the Aleph Symphony. Raydawn is also spending much of his time devising battle compositions for himself as well as other turntablists. He intends to scratch for the rest of his life as well as teach anyone who wishes to learn about the art form.

Ray can be reached at [djaydawn@battlesounds.com](mailto:djaydawn@battlesounds.com)